

0.50mm. HORIZONTAL SMT ZIF CONECTOR



0513 SERIE. 0.50mm(0.020"). For PCB solder

Features

- Available in 5 to 33 circuits
- Material: nylon 6/6 UL 94V-0
- Contact: Tin-lead plated phosphor bronze
- Zero insertion force and high contact pressure
- Applicable FPC and FFC: Thickness 0.30 mm
- It full fills RoHS norms

Dimensional Information

Ordering and Dimensional Information

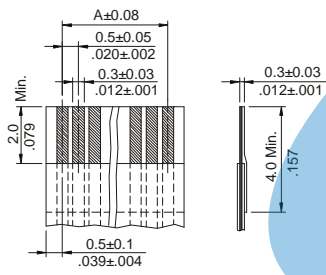
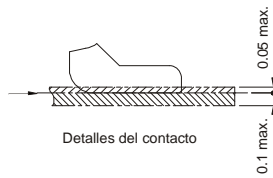
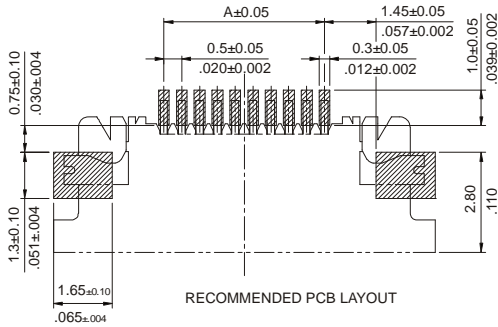

ACCOMMODATED FFC/FPC

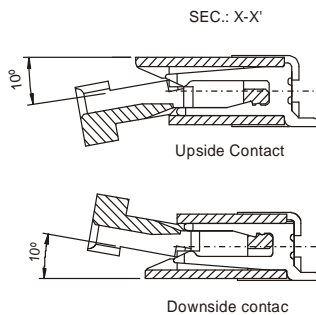

Circuit Size	Part Number		Dimensions		
	Upside Contact	Downside Contact	A	B	C
05	0513-2051	0513-2052	2,00(0,079)	8,20(0,323)	3,10(0,122)
06	0513-2061	0513-2062	2,50(0,098)	8,70(0,343)	3,60(0,142)
07	0513-2071	0513-2072	3,00(0,118)	9,20(0,362)	4,10(0,161)
08	0513-2081	0513-2082	3,50(0,138)	9,70(0,382)	4,60(0,181)
09	0513-2091	0513-2092	4,00(0,157)	10,20(0,402)	5,10(0,201)
10	0513-2101	0513-2102	4,50(0,177)	10,70(0,421)	5,60(0,220)
11	0513-2111	0513-2112	5,00(0,197)	11,20(0,441)	6,10(0,240)
12	0513-2121	0513-2122	5,50(0,217)	11,70(0,461)	6,60(0,260)
13	0513-2131	0513-2132	6,00(0,236)	12,20(0,480)	7,10(0,280)
14	0513-2141	0513-2142	6,50(0,256)	12,70(0,500)	7,60(0,299)
15	0513-2151	0513-2152	7,00(0,276)	13,20(0,520)	8,10(0,319)
16	0513-2161	0513-2162	7,50(0,295)	13,70(0,539)	8,60(0,339)
17	0513-2171	0513-2172	8,00(0,315)	14,20(0,559)	9,10(0,358)
18	0513-2181	0513-2182	8,50(0,335)	14,70(0,579)	9,60(0,378)
19	0513-2191	0513-2192	9,00(0,354)	15,20(0,598)	10,10(0,398)
20	0513-2201	0513-2202	9,50(0,374)	15,70(0,618)	10,60(0,417)
21	0513-2211	0513-2212	10,00(0,394)	16,20(0,638)	11,10(0,437)
22	0513-2221	0513-2222	10,50(0,413)	16,70(0,657)	11,60(0,457)
23	0513-2231	0513-2232	11,00(0,433)	17,20(0,677)	12,10(0,476)
24	0513-2241	0513-2242	11,50(0,453)	17,70(0,697)	12,60(0,496)
25	0513-2251	0513-2252	12,00(0,472)	18,20(0,717)	13,10(0,516)
26	0513-2261	0513-2262	12,50(0,492)	18,70(0,736)	13,60(0,535)
27	0513-2271	0513-2272	13,00(0,512)	19,20(0,756)	14,10(0,555)
28	0513-2281	0513-2282	13,50(0,531)	19,70(0,776)	14,60(0,575)
29	0513-2291	0513-2292	14,00(0,551)	20,20(0,795)	15,10(0,594)
30	0513-2301	0513-2302	14,50(0,571)	20,70(0,815)	15,60(0,614)
31	0513-2311	0513-2312	15,00(0,591)	21,20(0,835)	16,10(0,634)
32	0513-2321	0513-2322	15,50(0,610)	21,70(0,854)	16,60(0,654)
33	0513-2331	0513-2332	16,00(0,630)	22,20(0,874)	17,10(0,673)

Nota: In case of connectors in reel (Automatic mounting), add an R at the end of code

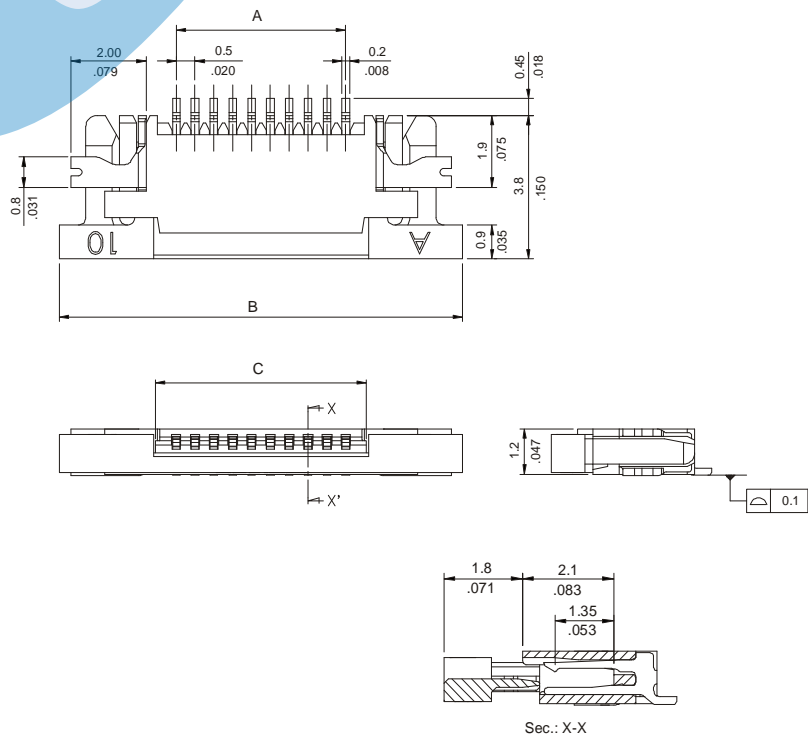

0.50mm. HORIZONTAL SMT ZIF CONECTOR



SERIE 0513. For Machine Mounting

Features

- Conectors presentation in reel
- Different lengths

Circuit Size	Dimensions				
	E	F	W1	W2	W3
6-22	24.0 (0.945)	-	24.50 (0.965)	30.50 (1.200)	24.50 (0.965)
23-32	32.0 (1.260)	28.40 (1.118)	32.50 (1.280)	38.50 (1.516)	32.50 (1.280)
33-50	44.0 (1.732)	40.40 (1.596)	44.50 (1.752)	50.50 (1.988)	44.50 (1.752)

