

5.08mm STRAIGHT PCB CONNECTOR



1507 SERIES. 5.08 mm. (0.200"). For PCB solder

Features

- Available in 2 through 20 circuits
- Insulator Material: Nylon 6/6 UL 94V-2
- For board to board applications
- Available with and without locking ramp
- Mates with 1.14mm (0.45") square or round pin
- Designed for parallel or right angle board stacking

Dimensional Information

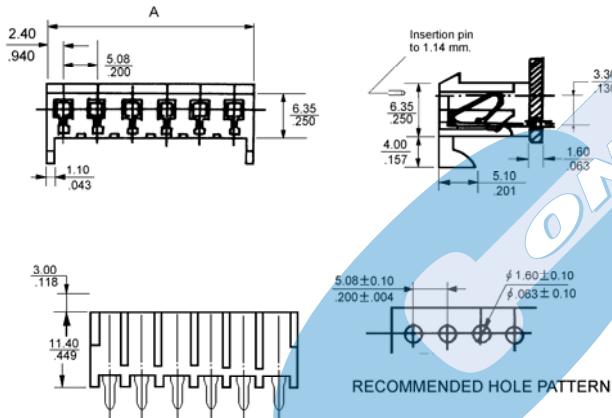

Ordering and Dimensional Information

| Circuit Size | Part Number | | Dimensions |
|--------------|-------------|--------------|---------------|
| | With ramp | Without ramp | |
| 02 | 1507- 2021 | 1507- 2022 | 10,16(0,400) |
| 03 | 1507- 2031 | 1507- 2032 | 15,24(0,600) |
| 04 | 1507- 2041 | 1507- 2042 | 20,32(0,800) |
| 05 | 1507- 2051 | 1507- 2052 | 25,40(1,000) |
| 06 | 1507- 2061 | 1507- 2062 | 30,48(1,200) |
| 07 | 1507- 2071 | 1507- 2072 | 35,56(1,400) |
| 08 | 1507- 2081 | 1507- 2082 | 40,64(1,600) |
| 09 | 1507- 2091 | 1507- 2092 | 45,72(1,800) |
| 10 | 1507- 2101 | 1507- 2102 | 50,80(2,000) |
| 11 | 1507- 2111 | 1507- 2112 | 55,88(2,200) |
| 12 | 1507- 2121 | 1507- 2122 | 60,96(2,400) |
| 13 | 1507- 2131 | 1507- 2132 | 66,04(2,600) |
| 14 | 1507- 2141 | 1507- 2142 | 71,12(2,800) |
| 15 | 1507- 2151 | 1507- 2152 | 76,20(3,000) |
| 16 | 1507- 2161 | 1507- 2162 | 81,28(3,200) |
| 17 | 1507- 2171 | 1507- 2172 | 86,36(3,400) |
| 18 | 1507- 2181 | 1507- 2182 | 91,44(3,600) |
| 19 | 1507- 2191 | 1507- 2192 | 96,52(3,800) |
| 20 | 1507-2201 | 1507-2202 | 101,80(4,000) |