

SINGLE ROW FEMALE HEADER



2101 SERIES. 2.54mm(0.100"). For PCB Solder

Features

- Available in 2 through 40 circuits
- Insulator Material: PBT UL 94V-0
- Mates with 2.54mm pitch and 0.64mm square or round pin header
- Profile: 8.50mm

- Low profile and High density is suitable for devices which require small and light internal parts
- High reliability contact structure provides normal insertion force after repeated cycles
- For other options consult the Sales Office

Dimensional information

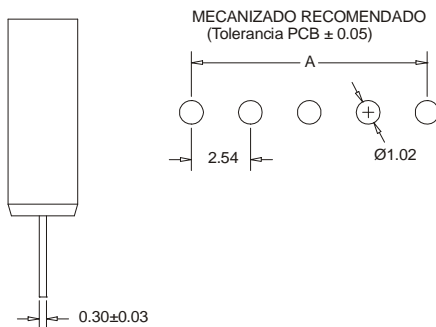
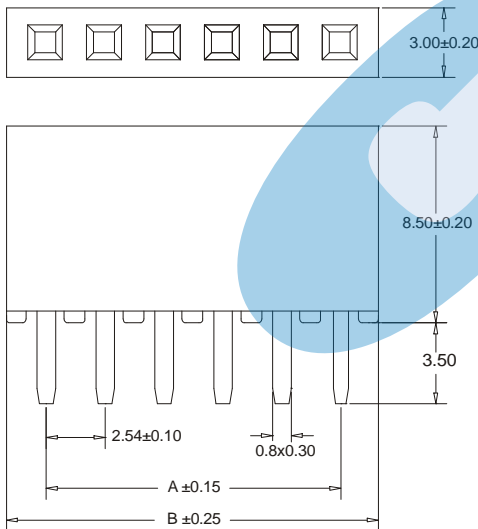
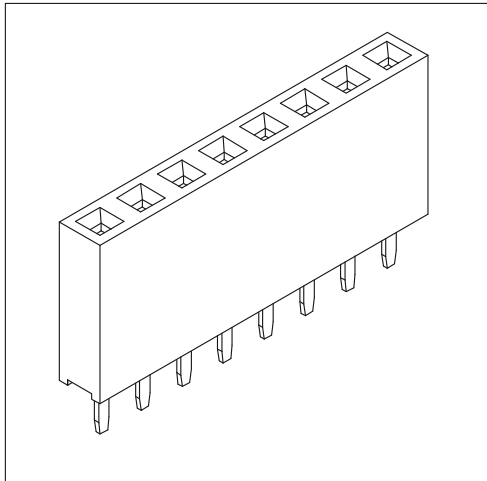

Ordering and dimensional information

Circuit Size	Part Number	Dimensions	
		A	B
02	2101 - T021	2,54(0,100)	5,88(0,231)
03	2101 - T031	5,08(0,200)	8,42(0,331)
04	2101 - T041	7,62(0,300)	10,96(0,431)
05	2101 - T051	10,16(0,400)	13,50(0,531)
06	2101 - T061	12,70(0,500)	16,04(0,631)
07	2101 - T071	15,24(0,600)	18,58(0,731)
08	2101 - T081	17,78(0,700)	21,12(0,831)
09	2101 - T091	20,32(0,800)	23,66(0,931)
10	2101 - T101	22,86(0,900)	26,20(1,031)
11	2101 - T111	25,40(1,000)	28,74(1,131)
12	2101 - T121	27,94(1,100)	31,28(1,231)
13	2101 - T131	30,48(1,200)	33,82(1,331)
14	2101 - T141	33,02(1,300)	36,36(1,431)
15	2101 - T151	35,56(1,400)	38,90(1,531)
16	2101 - T161	38,10(1,500)	41,44(1,631)
17	2101 - T171	40,64(1,600)	43,98(1,731)
18	2101 - T181	43,18(1,700)	46,52(1,831)
19	2101 - T191	45,72(1,800)	49,06(1,931)
20	2101 - T201	48,26(1,900)	51,60(2,031)
21	2101 - T211	50,80(2,000)	54,14(2,131)
22	2101 - T221	53,34(2,100)	56,68(2,231)
23	2101 - T231	55,88(2,200)	59,22(2,331)
24	2101 - T241	58,42(2,300)	61,76(2,431)
25	2101 - T251	60,96(2,400)	64,30(2,531)
26	2101 - T261	63,50(2,500)	66,84(2,631)
27	2101 - T271	66,04(2,600)	69,38(2,731)
28	2101 - T281	68,58(2,700)	71,92(2,831)
29	2101 - T291	71,12(2,800)	74,46(2,931)
30	2101 - T301	73,66(2,900)	77,00(3,031)
31	2101 - T311	76,20(3,000)	79,54(3,131)
32	2101 - T321	78,74(3,100)	82,08(3,231)
33	2101 - T331	81,28(3,200)	84,62(3,331)
34	2101 - T341	83,82(3,300)	87,16(3,431)
35	2101 - T351	86,36(3,400)	89,70(3,531)
36	2101 - T361	88,90(3,500)	92,24(3,631)
37	2101 - T371	91,44(3,600)	94,78(3,731)
38	2101 - T381	93,98(3,700)	97,32(3,831)
39	2101 - T391	96,52(3,800)	99,86(3,931)
40	2101 - T401	99,06(3,900)	102,40(4,031)

T = Contact Plating

- T = 2. Tin plated
- T = 3. Gold flash over 50µ" nickel
Recommended Finish
- T = 5. 15µ" gold over 50µ" nickel
- T = 6. 30µ" gold over 50µ" nickel
- T = 13. Selective gold flash over 50µ" nickel
- T = 15. 15µ" selective gold over 50µ" nickel
- T = 16. 30µ" selective gold over 50µ" nickel