

2.54mm DUAL ROW FEMALE HEADER



2202 SERIES. 2.54 x 2.54mm(0.100 x 0.100"). For PCB Solder

Features

- Available in 4 through 80 circuits
- Insulator Material: Glass filled polyester UL 94V-0
- Mates with 2.54mm pitch and 0.64mm pin headers
- Dual beam phosphor bronze contacts
- Height: 7.10mm
- Different plating options are available
- With standoff minimise flux retention
- Designed for board to board small spacing interconnection

Dimensional Information

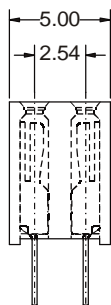
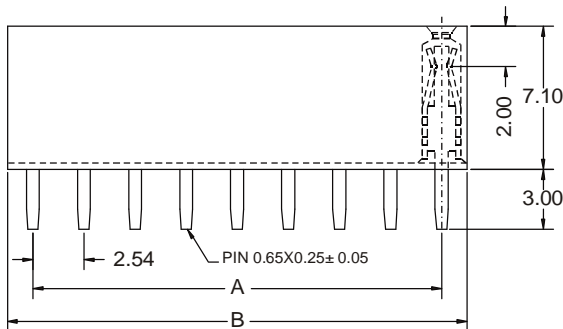
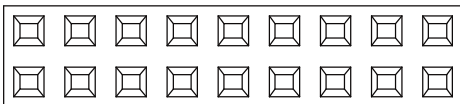
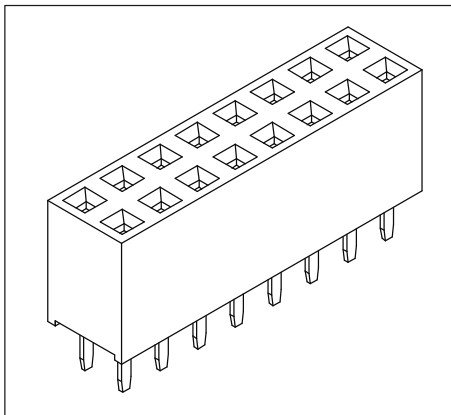

RECOMMENDED HOLE PATTERN

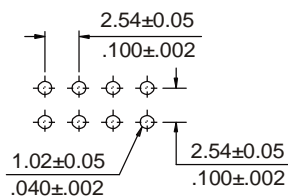

Ordering and Dimensional Information

Circuit Size	Part Number	Dimensions	
		A	B
04	2202-T041	2,54(0,100)	5,08(0,200)
06	2202-T061	5,08(0,200)	7,62(0,300)
08	2202-T081	7,62(0,300)	10,16(0,400)
10	2202-T101	10,16(0,400)	12,70(0,500)
12	2202-T121	12,70(0,500)	15,24(0,600)
14	2202-T141	15,24(0,600)	17,78(0,700)
16	2202-T161	17,78(0,700)	20,32(0,800)
18	2202-T181	20,32(0,800)	22,86(0,900)
20	2202-T201	22,86(0,900)	25,40(1,000)
22	2202-T221	25,40(1,000)	27,94(1,100)
24	2202-T241	27,94(1,100)	30,48(1,200)
26	2202-T261	30,48(1,200)	33,02(1,300)
28	2202-T281	33,02(1,300)	35,56(1,400)
30	2202-T301	35,56(1,400)	38,10(1,500)
32	2202-T321	38,10(1,500)	40,64(1,600)
34	2202-T341	40,64(1,600)	43,18(1,700)
36	2202-T361	43,18(1,700)	45,72(1,800)
38	2202-T381	45,72(1,800)	48,26(1,900)
40	2202-T401	48,26(1,900)	50,80(2,000)
42	2202-T421	50,80(2,000)	53,34(2,100)
44	2202-T441	53,34(2,100)	55,88(2,200)
46	2202-T461	55,88(2,200)	58,42(2,300)
48	2202-T481	58,42(2,300)	60,96(2,400)
50	2202-T501	60,96(2,400)	63,50(2,500)
52	2202-T521	63,50(2,500)	66,04(2,600)
54	2202-T541	66,04(2,600)	68,58(2,700)
56	2202-T561	68,58(2,700)	71,12(2,800)
58	2202-T581	71,12(2,800)	73,66(2,900)
60	2202-T601	73,66(2,900)	76,20(3,000)
62	2202-T621	76,20(3,000)	78,74(3,100)
64	2202-T641	78,74(3,100)	81,28(3,200)
66	2202-T661	81,28(3,200)	83,82(3,300)
68	2202-T681	83,82(3,300)	86,36(3,400)
70	2202-T701	86,36(3,400)	88,90(3,500)
72	2202-T721	88,90(3,500)	91,44(3,600)
74	2202-T741	91,44(3,600)	93,98(3,700)
76	2202-T761	93,98(3,700)	96,52(3,800)
78	2202-T781	96,52(3,800)	99,06(3,900)
80	2202-T801	99,06(3,900)	101,60(4,000)

T = Contact Plating

- T = 2. Tin plated
- T = 3. Gold flash over 50µ" nickel
Recommended Finish
- T = 5. 15µ" gold over 50µ" nickel
- T = 6. 30µ" gold over 50µ" nickel
- T = 13. Selective gold flash over 50µ" nickel
- T = 15. 15µ" selective gold over 50µ" nickel
- T = 16. 30µ" selective gold over 50µ" nickel