

H/ PROFILE PCB MOUNT D-SUB RECEPTACLE



8019 SERIE. For PCB Solder

Features

- Available in 9, 15, 25 and 37 circuits
- Insulator Material: Glass filled Polyester UL 94V-0
- Contact Material: Phosphor Bronze
- Different plating options are available
- Shell: Steel, tin plated as standard
- Optional: #4-40 UNC hexagonal standoff or clinch nuts
- Other options: Hoods, mounting screw and accessories
- For other options consult the Sales Office

Dimensional Information

Ordering and Dimensional Information

Circuit Size	Part Number	Dimensions			
		A	B	C	D
9	8019 - 109C	16.33 (0.643)	24.99 (0.984)	30.81 (1.213)	19.23 (0.757)
15	8019 - 115C	24.66 (0.971)	33.32 (1.312)	39.14 (1.541)	27.56 (1.085)
25	8019 - 125C	38.38 (1.511)	47.04 (1.852)	53.04 (2.088)	41.28 (1.625)
37	8019 - 137C	54.84 (2.159)	63.50 (2.500)	69.32 (2.729)	57.73 (2.273)

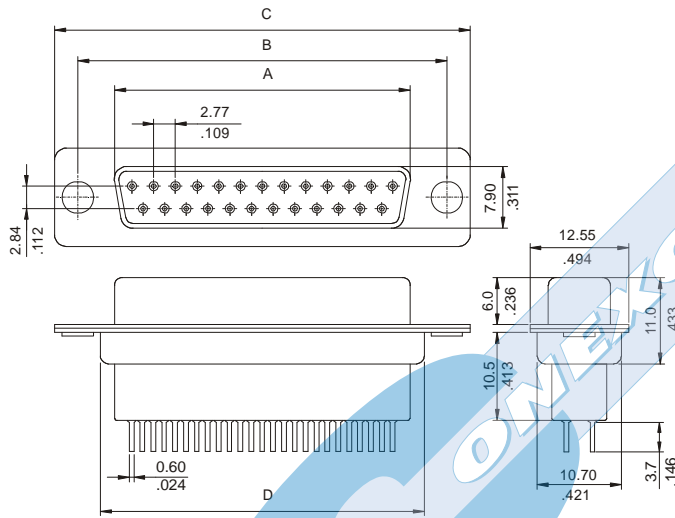

T = Contact Plating

- T = 3. Gold flash over 50µ" nickel.
- T = 5. 15µ" gold over 50µ" nickel
- T = 6. 30µ" gold over 50µ" nickel

C = Hardware Options

- C = 1. Standard with 3.05mm(.012") diameter mount hole
- C = 3. Version T2
- C = 4. Version T1
- C = 5. Version D2

RECOMMENDED HOLE PATTERN

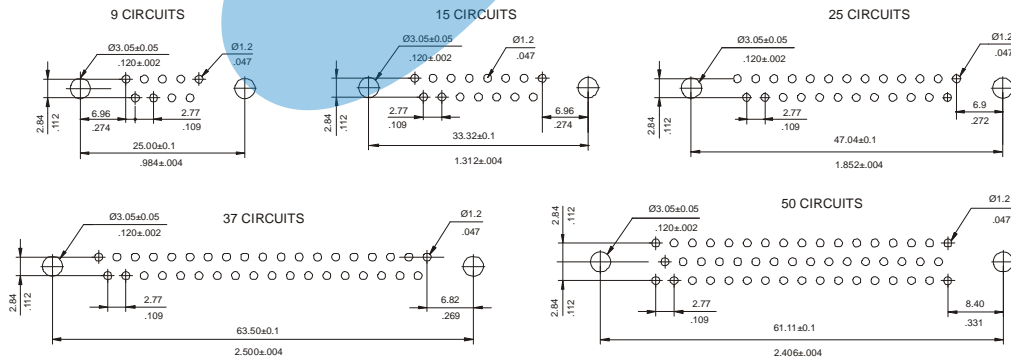

C = HARDWARE OPTIONS

